

# KEYSTONE REVIEW

APRIL

MAY

JUNE

2006

## Davis-Standard, LLC to Make Strong Showing at NPE

**D**avis-Standard, LLC will exhibit several new extrusion and converting technologies at **booth #5107** during NPE 2006. This is the first major show for Davis-Standard, LLC since the Davis-Standard and Black Clawson Converting Machinery merger last summer, and the acquisition of Merritt Extruder Corporation. Equipment from the Davis-Standard, Black Clawson Converting Machinery, Egan, Merritt and Killion product lines will be displayed including extruders, control systems and complete lines. Following are some examples:

- A new **seven-layer blown film system** with "Super-Cooled" MAC extruders, a low profile seven-layer die with automatic air ring, and a 64-inch (1,625mm) dual turret winder;
- A **blow molding head with new 3DX deformable die ring technology** and a MACO 6500 RS controls system;
- The new **Integrator PRO** for complete line control of converting processes as well as information on the **Integrator C** upgrade and/or replacement package for existing systems such as the Egan "CMR" and ER-WE-PA "Exact P";
- New, cost-effective **DS-TPC** discrete control technology for extrusion processes;
- The new **XP Express™ roll stand system** for sheet and packaging



- applications;
- A running **laboratory QC line with a horizontal extruder and FPV pump**;
- New **adjustable and horizontal extruders** with a small footprint and gearless direct drive motor, and a larger **4 1/2-inch (114mm) Super Blue® extruder** model;
  - An **ELF (Elastomer Leakage Free) feed section and torque motor extruder**; and
  - A running **line for producing cotton swab sticks with an all-in-one Betopack machine** for pulling, cutting and packing small serrated tubes.

In addition to equipment, Davis-Standard will have several displays showing end products, spare parts and feedscrews. Computerized demonstrations and a corporate capabilities DVD will promote product lines not being shown. In addition, Davis-Standard will have information on the implementation of 24/7 customer service for its Extrusion Systems Group, making the 24/7 service companywide for both extrusion and converting customers in North America. Extrusion Systems will also have an on-line parts ordering system demonstration. For more information prior to the show, visit [www.davis-standard.com](http://www.davis-standard.com) (Extrusion Systems) or [www.bc-egan.com](http://www.bc-egan.com) (Converting Systems).

## Extrusion Lab Equipped for Sophisticated R&D Applications

**T**he Converting Systems Group of Davis-Standard, LLC recently upgraded and expanded the machinery capabilities at its extrusion pilot lab in Fulton, New York, to create one of the nation's most versatile R&D facilities for converting processes. The lab, equipped with a Black Clawson Converting Machinery (BCCM) coextrusion

line, is geared toward multiple applications including cast polypropylene films, stretch wrap, packaging films, flexible packaging and board coating. Customers can take advantage

of a system engineered for accuracy, speed and tension control for new product/process development, resin and equipment experimentation and a host of other trial-based and production uses. The line incorporates the latest AC vector drive technology from SSD Drives, and the line's robotic winder utilizes the latest Allen-Bradley servo drives system for high speed, high torque spindle positioning with accurate position feedback via fiber optic communications.

"This lab is 80 percent dedicated to customer



The lab's coextrusion line is equipped for multiple converting applications including cast polypropylene film, stretch wrap, packaging films, flexible packaging and board coating.

Extrusion Lab continued on page 6

## IN THIS ISSUE

- New Extruders and Betopack Highlight Pipe and Profile Display
- Blow Molding Head with 3DX Technology
- New Seven-Layer Blown Film Line
- Integrator C replaces Egan CMR
- New DS-TPC Control System
- PRI Capitalizes on Fencing Market
- Davis-Standard Opens New Sales Office in China

**On Time,  
Every Time** **24/7  
Support**

Extrusion Systems: +1 800-480-8105  
Converting Systems: +1 800-338-3660

**D-S Davis-Standard®**

# New Extruders and Betopack Highlight Pipe and Profile Display

**A** new compact extruder design and larger version of the popular Super Blue® extruder will be introduced at NPE. Davis-Standard, LLC will also show a running line with a Betopack unit for manufacturing cotton swab sticks, and a GC-61 extruder for custom profiles. Following is information on each.

## **DS Adjustable and Horizontal Extruders—**

Davis-Standard will show examples of a new line of 3/4-inch (19mm) to 1 3/4-inch (44mm) extruders available in an adjustable or horizontal configuration. A 1 1/4-inch (32mm) and 1 1/2-inch (38mm) adjustable extruder and a 1 1/2-inch (38mm) horizontal extruder will be on display. These machines utilize a direct drive motor versus belts and sheaves, and are built on a smaller footprint than previous Davis-Standard designs. Fast delivery is another advantage not previously offered for machines of this size. Extruders in stock can be delivered in one to two weeks from order placement. All non-stock machines are available in three to four weeks. Davis-Standard utilizes common components such as gearcases, feedsections and barrels on both the horizontal and adjustable models.

**Super Blue® Extruder** – The cost-effective and versatile Super Blue extruder will be shown in a new 4 1/2-inch (114mm) 24:1 L/D model. Davis-Standard recently added a 4 1/2-inch (114mm) and 100mm model to its popular Super Blue product line. Both models are available in 24:1 and 30:1 L/D ratios. The 100mm extruders are equipped with a 150 HP AC drive. The 4 1/2-inch (114mm) 24:1

extruder is available with a 200 HP AC drive and the 30:1 version has a 250 HP AC drive. As with the company's other Super Blue extruders, in stock machines will have a short lead time of one to two weeks from order placement. Machines not in stock will be available in three to four weeks from order placement. Up to this point, the Super Blue was available in 2-inch (50mm), 2 1/2-inch (65mm), 75mm and 3 1/2-inch (90mm) sizes, each with a 24:1 L/D ratio. The addition of the larger Super Blue extruders further promotes Davis-Standard's ability to provide quality machines with a fast delivery and competitive pricing.

**Betopack Running Line** – A running line with an all-in-one Betopack machine for pulling, cutting and packing small serrated tubes will manufacture cotton swab sticks during NPE. The Betopack is capable of packaging up to 4,500 sticks per minute, but will package around 2,000 to 2,500 sticks per minute at the show. This machine simplifies the downstream process by automatically placing sticks into a tray or box and staging them for a secondary process. The sticks at the show will have a 2.5mm nominal OD, 1.9mm ID and length of 72mm with an OD tolerance of +/- .05mm and cut length tolerance of +/- .5mm. Davis-Standard will run polypropylene with an MFI of between 3.0 and 3.5. The line will be powered by a 2 1/2-inch (60mm) 24:1 Super Blue extruder capable of

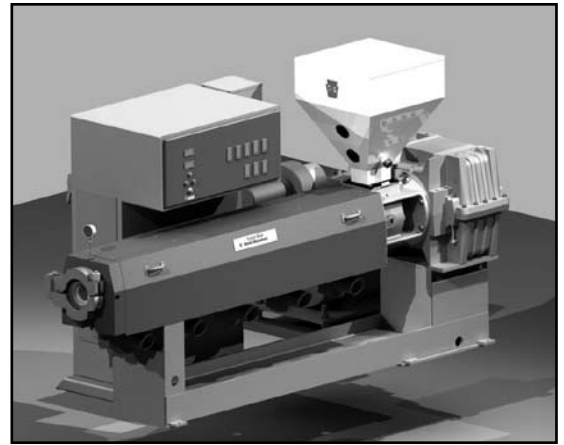

The larger version of Davis-Standard's Super Blue® is available in a 4 1/2-inch (114mm) and 100mm model.

processing 130 pounds of polypropylene per hour at a 100 RPM screw speed. A 20-foot vacuum tank courtesy of Conair and a die with calibration tooling supplied by Davis-Standard's facility in Germany will also be shown.

**GC-61 Extruder** – Davis-Standard's Gemini® Conical (GC) 61mm twin screw extruder is primarily used for custom window and door profiles, vertical blinds, capstock coextrusion and materials development, and quality control lab usage. The extruder's high performance gearbox has twice the thrust and torque capacity of competitive models. Low rpm screws with an internal sealed water cooling system enable the GC-61 to efficiently process RPVC powder formulations. Nominal rpm production rates for the GC-61 are nearly 500 pounds (230 kg) per hour. The "GC" series, also available in a 40mm model and a 65mm model, are built on a single base with alternate drive positioning and sizing to provide a great deal of flexibility.

# Davis-Standard Blow Molding Head to Feature 3DX Technology

**D**avis-Standard's blow molding head at NPE will include the new 3DX deformable die ring technology from BMC Controls Ltd. of the United Kingdom. The 8-lb head being shown is engineered for blow molding industrial containers, and is well suited for the 3DX system which optimizes material distribution for high performance applications. The 3DX is an alternative to existing PWDS technology, offering a unique flexible die ring for improved control of radial wall thickness.

Advantages of the system include innovative cylinder mounting to reduce heat from the head to avoid damage to cylinder seals; a new hydraulic safety function to prevent flexible die damage on accidental cold starts; and a proportional push-out mechanism to improve efficiencies on accumulator head machines. Unlike competitive systems, the flexible ring, hydraulic cylinders and mounting features of the 3DX enable end-users to service the system

themselves. This technology combined with the quick color changeover and parison control of Davis-Standard's accumulator head technology produces a consistent and cost effective blow molded part.

Also being shown is Davis-Standard's MACO 6500 RS control system. Standard features include a Windows® 2000 Pro operator's interface with network connectivity. Other features include distributive controls for simplified wiring, three modes of closed loop shoot/fill, and adaptive extruder speed control. In addition, digital on-demand heater amp scan, statistical process control (SPC), data trending and custom tailored security levels enhance close process control. The system can easily be adapted to fit specialized applications.

For more information prior to NPE, contact Frank Kennedy at [fkennedy@davis-standard.com](mailto:fkennedy@davis-standard.com).



BMC "3DX" deformable die ring for blow molding machines.

# New Seven-Layer Blown Film Line to Debut at NPE

Davis-Standard, LLC will display a new seven-layer blown film system at NPE that illustrates the strength of the Converting Systems Group. The system is equipped with advanced extruder, die, air ring, winder and control technology to improve production efficiencies and rates for simple or complex blown film structures.

The line includes seven "Super-Cooled" MAC extruders with an air volume system significantly more powerful than previous models. The cooling mimics the efficiency of water cooling without the maintenance issues of water. The aerodynamic design of the extruder base contributes to the effectiveness of this cooling system. This leads to cooler melt temperatures, stronger film, thinner gauges and higher rates. These extruders are also available with a direct motor to screw connection.

Connecting the extruders is a 14-inch (355mm), seven-layer Lo Pro coextrusion die with highly efficient flow channels, heating and IBC features. The WesJet AutoPro air ring completes this arrangement with a gauge variation of better than three percent for typical film production.

Also being shown is an Integrator PRO supervisory control system and Model 1450

dual turret winder. The recently introduced Integrator PRO serves as the visual link between the operator and the process, providing complete line control via sophisticated graphics and start-up menus accessed through a user-friendly operator interface powered by Microsoft® Windows® XP. The 64-inch (1,625mm) Model 1450 dual turret winder features dual direction auto transfer as well as a horizontal lay-on carriage that is servo driven for precise lay-on pressure and gap winding. The winder's phantom axis design enables winding of 32-inch (800mm) diameter rolls. This winder will be available for immediate sale at the show.

In addition, a new range of winders with automation and custom features for stretch wrap, hygienic films, high-speed foil unwinding, combo winding, robotic winding, no tension winding and general purpose applications will

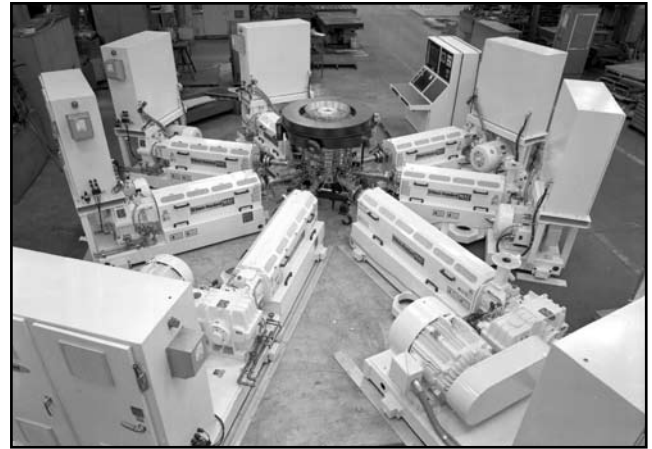

The line features seven "Super-Cooled" MAC extruders connected by a seven-layer Lo Pro coextrusion die.

be graphically represented.

From the hopper to the winding spindle, Davis-Standard's experts will be available to address any improvements you may need in your process. For more information about this line or the blown film capabilities of Davis-Standard's Converting Systems Group, contact Rick Keller at [rkeller@davis-standard.com](mailto:rkeller@davis-standard.com).

## Running Lab QC Line at NPE

The capabilities of a running laboratory resin quality control line will be shown during NPE. The line will include an FPV (filter pressure value) pump system and a roll stand with a gel detection camera. The extruder, a new horizontal model, will be running polypropylene resins during the show. The extruder is adaptable for virtually any laboratory application.

The new FPV pump improves quality control testing of materials that require consistent and thorough mixing by providing accurate and repeatable pressure measurement. It is an essential tool for compounders, especially color compounders, as it provides a filter pressure value to quantify the level of resin dispersibility. This value helps maintain product consistency and provides a standardized,

globally-recognized method of comparing one product to another. It is also more accurate than the ASTM test previously used. The FPV unit includes a melt pump, adaptors, control panel, motor and drive, filter screen holder (die), pressure display and stand/support frame. Options include closed loop pressure control, data ready capabilities for attachment to an existing computer, or an integrated Data-Pack data acquisition system.

The laboratory roll stand being shown features 8-inch (200mm) by 5-inch (127mm) diameter rolls. It will be equipped with the company's camera-based gel detection and measurement system. For more information prior to the show, contact Simon Dominey at [sdominey@davis-standard.com](mailto:sdominey@davis-standard.com).

## Integrator C Replaces Egan CMR Technology

The Converting Systems Group now offers a direct replacement for its Egan CMR supervisory control unit, the Integrator C. This new single-point control system provides the functionality of the CMR with additional features including recipe management, historical data trending and alarms. The Integrator C also features die control, a new PLC drives interface, improved temperature controls and enhanced gauge control based on the age of the existing gauge system.

Converters have multiple replacement options available to best accommodate system requirements and budget parameters. Complete drives upgrades are available for CMR drive systems between 12 and 15 years old. The first option includes a DC drives upgrade and re-use of existing motors. The second option includes an upgrade to AC drives and motors, which equates to increased savings in the long run. For machines with PLC's older than 15 to 20 years, several upgrades are available to improve machine performance, minimize downtime and provide added process control capabilities based on converting application.

To find out how you can replace or upgrade your CMR system with Integrator C technology, contact Tarek Adly at [adlyt@bc-egan.com](mailto:adlyt@bc-egan.com) or Tony Scott at [scottt@bc-egan.com](mailto:scottt@bc-egan.com).

## Davis-Standard Feedscrews on Sale

To reduce its feedscrew inventory, Davis-Standard, LLC is offering more than 25 feedscrew designs at significantly reduced prices. Feedscrews for a variety of applications and resins are available in sizes ranging from 3/4-inch to 3 1/2-inches (19 to 90mm). Examples include metering screws, DSB® screws with spiral mixers, low work RPVC barrier screws, DSB high work FPVC screws and rubber screws. Available feedscrews are for Davis-Standard extruders only and can be viewed online at [www.davis-standard.com](http://www.davis-standard.com). Under the "R&D/Technology/Services" heading, click on the link that reads

"Special Screw Prices." There you will find a complete listing and description of available feedscrews as well as photos and pricing.

"We manufactured additional screws to support our large base of extruders in the field and our inventory simply got overstocked. This is a great time for our customers to purchase new or replacement feedscrews at very good prices," explained Rick Stannard, manager of Davis-Standard's inter-company sales.

For more information on the feedscrew sale and availability, contact Rick Stannard at [rstannard@davis-standard.com](mailto:rstannard@davis-standard.com) or (860) 599-6203.

# Davis-Standard Extruder Technology and Aftermarket Services Promoted at NPE

A range of technologies and aftermarket services for its Extrusion Systems Group will be promoted at NPE. This includes an ELF feed section, torque motor extruder and several feedscrews. Davis-Standard will also have a computerized visual representation of an air-cooled extruder. Trade show visitors will have access to a computer program enabling them to disassemble and reassemble the extruder to see gears, bearings and other features. In addition, Davis-Standard will highlight aftermarket services for its Extrusion Systems Group including a 24/7 response line and a more convenient spare parts ordering service. A parts display of commonly ordered parts will also be featured. Following are details about what is being shown.

**ELF Feed Section** – The 3 1/2-inch (90mm) “Elastomer Leakage Free” (ELF) feed section being shown reduces scrap problems and feed roll bearing failure associated with rubber bleed during the extrusion process. This patent-pending machine feeds rubber shavings scraped from the feed roll directly back into the process, reducing waste and protecting feed roll bearings from contamination. The feed roll cartridge is on a removable assembly for accessible and convenient maintenance. To accurately calibrate blade-to-roll dimensions, the scraper blade can be adjusted on the assembly when it is out of the machine and visible. The ELF is available on new 2 1/2-inch (65mm), 3 1/2-inch (90mm), 4 1/2-inch (115mm) and 6-inch (150mm) Davis-Standard extruders. It can also be retrofitted onto existing extruders as a direct replacement component.

**Torque Motor Extruder** – This 75mm extruder features a compact torque motor that combines both gearbox and motor functions into one highly efficient unit. Design advantages

include a hollow shaft, water cooling, fewer mechanical components and high rigidity. Operating benefits include low machine noise, reduced maintenance, flexible installation, increased repeatability and a screw speed capacity between 200 and 300 rpm. This motor also enables processors to remove the screw from the rear of the extruder, preventing disruption of downstream equipment.

**Aftermarket Services** – Information on the 24/7 customer service line and improved parts ordering procedures for the Extrusion Systems Group will be available during NPE. The 24/7 service provides a dedicated response line for parts and service, available 24 hours a day, seven days a week. A toll free number – **(800) 480-8105** – is set up to assist customers from coast to coast and continent to continent. This number services the fiber, sheet, elastomer, laboratory and specialty systems, wire and cable, pipe, profile and tubing, compounding, recycle and reclaim process areas. Customers will have immediate access to a parts or service technician to handle parts inquiries and emergency service needs. Parts shipments, if in stock, can be shipped within one day. On-site service by a

Davis-Standard's torque motor extruder combines gearbox and motor functions into one highly efficient unit.

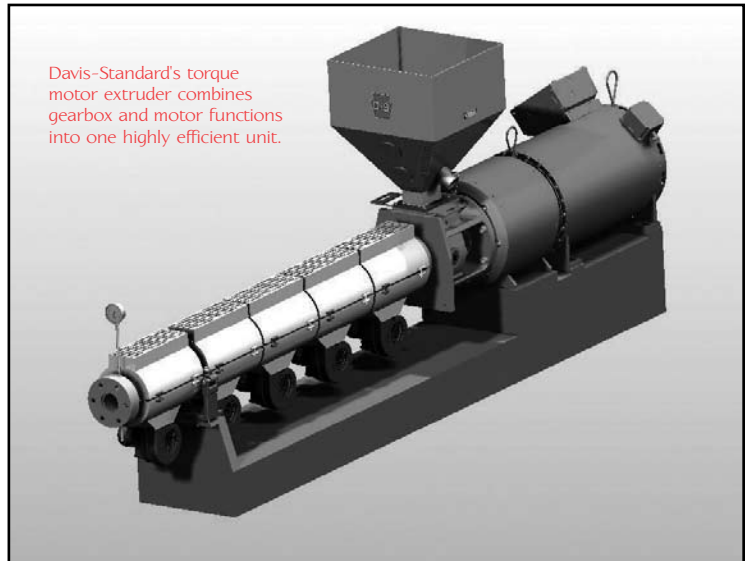

technician is also available on an expedited basis.

In addition, Davis-Standard's Extrusion Systems Group is implementing a more convenient procurement option by accepting VISA®, MasterCard®, and American Express® for telephone, fax, online and e-mail orders. This service will better facilitate customer purchases for frequently ordered spare parts such as rupture discs, swing gate bolts and nuts, cast aluminum heaters, band heaters, thermocouples and temperature controllers. Parts for the company's Extrusion Systems product line including NRM, Killion, Davis-Standard and Merritt Extruder brands can be ordered between 8 a.m. and 7 p.m. Eastern time, Monday through Friday. In a few months, parts will also be available online by going to [www.davis-standard.com](http://www.davis-standard.com). Additional details about the new services will be available at the show.

## New DS-TPC Discrete Control System

The new DS-TPC (touch panel control) control system will be introduced at NPE. This system is engineered to replace other discrete devices such as discrete temperature controllers, pressure indicators/controllers and drive operators/indicators at the same base price and functionality with the added benefit of coordinated drive control to a one-line drive.

Other features include cold start inhibit, high and high-high alarms for each pressure point, recipe creation and storage, and a provision for system networking to a supervisory computer via Ethernet LAN. The DS-TPC includes a 12.1-inch (307mm) color touch screen with built-in PLC processor, sub-panel mounted temperature control and PLC I/O modules. It is offered in three pre-configured and

engineered levels with options for additional heating and cooling zones, additional temperature monitors, melt pump closed loop pressure control, and secondary extruder control for small co-extrusion systems.

For more information about the DS-TPC, contact John Clemens at [jclemens@davis-standard.com](mailto:jclemens@davis-standard.com).

The DS-TPC gives processors the advantages of integrated touch-screen control at discrete pricing.

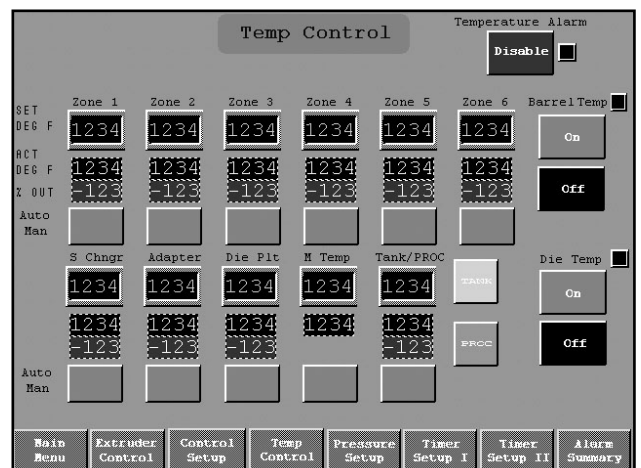



## Davis-Standard News Briefs

### Davis-Standard Parts Service for Pipe, Profile & Tubing Moves Back to UK

To further strengthen customer service and support, Davis-Standard, LLC is relocating the spare parts business for its pipe, profile and tubing equipment in Europe to its D-S Brookes Ltd. facility in Oldbury, United Kingdom. This includes spare parts for the Betol Machinery, Francis Shaw Plastics Machinery, Kabel Teknik and Floataire product lines. The relocation will take place over the next few months with services fully operational by May.

In addition to the spare parts business, D-S Brookes will continue to grow its bimetallic barrel and feedscrew manufacturing operation. D-S Brookes manufactures bi-metallic barrels and liners for wear, corrosion resistance and extreme applications such as highly filled processes. In the area of screw production, D-S Brookes machines standard application finished screws through flight tipping as well as fully encapsulated screws. The Oldbury facility will also continue to offer service and parts support to European customers with Davis-Standard equipment manufactured in the United States.

For more information about Davis-Standard's aftermarket services in Europe and at D-S Brookes, contact Mark Woodgate on +44(0)7801-197751 or by e-mail at mrwdsld@aol.com.

D-S Brookes offices are at 33 Hainge Road, Oldbury, West Midlands B69 2NY, United Kingdom. Telephone: +44(0)121-522-0030, Fax: +44(0)121-522-0031.

## Davis-Standard, LLC Opens New Sales Office in China

A newly opened office in Shanghai, China will help Davis-Standard, LLC support existing and potential business in the growing Chinese marketplace. The Shanghai location will provide localized customer service and support to customers throughout China and other parts of Asia while building relationships with sales representatives, government institutes and associations. This office will also be responsible for coordinating and implementing parts and components sourcing in the region, and participating in influential tradeshows and seminars.



Pictured from left to right are Andrew Sun, Susan Guo and Edward Zhang at the new Shanghai office.

Davis-Standard's key personnel at this office include Andrew Sun, business manager, China; Edward Zhang, business development and sales/sourcing representative; and Susan Guo, business assistant. The contact information for the Shanghai office is as follows:

Davis-Standard, LLC  
Shanghai Representative  
Room 1007, Jing An China Tower  
No. 1701 Beijing (W) Road  
Shanghai 2000040, PR China  
Tel: +86-21-5150 1908  
Fax: +86-21-5150 1906  
E-mail: andrew.sun@davis-standard.com.cn

This office represents all Davis-Standard, LLC product lines within the company's Extrusion Systems and Converting Systems business groups. Products offered include equipment for blown film, cast film, extrusion coating, laminating, laboratory, sheet, pipe, profile and tubing, elastomer and wire and cable processes. For more information, contact Andrew Sun at andrew.sun@davis-standard.com.cn.

## Jerry Warren and Paul Chang Join Davis-Standard, LLC

Davis-Standard, LLC is pleased to welcome Jerry Warren as business director-aftermarket. Warren will be responsible for aftermarket sales of the Davis-Standard Extrusion Systems Group, including parts, rebuilds and upgrades.

Warren comes to Davis-Standard after six years as a managing partner with New Harbour, Inc. in Fall River, Massachusetts. Prior to his work in starting and operating New Harbour, he held numerous financial and general management positions with John Brown Plastics Machinery. His last assignment with John Brown was as vice president of aftermarket sales for Cumberland, a manufacturer of granulation equipment for the plastics industry. Warren is a graduate of the University of North Carolina at Chapel Hill and received his MBA from The Wharton School at the University of Pennsylvania.



Paul Chang has joined Davis-Standard, LLC as a sourcing specialist based in Beijing, China. Chang will be responsible for sourcing components insuring that the components meet specifications and are delivered to Davis-Standard in a timely manner. One of his priorities will be to improve communication and parts inspection in the region.

Chang has a solid background in both electrical and mechanical components and will be based from a home office in Beijing. He has more than 10 years of experience sourcing and inspecting parts in China, most recently with First Galaxy Corporation sourcing steel and aluminum castings. Chang has a Bachelor's Degree in Electrical Engineering from Southeast University in Nan Jing.

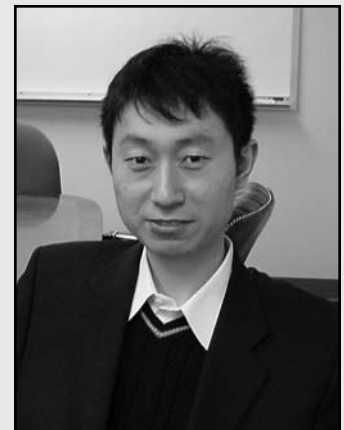

# PRI Capitalizes on Fencing Market with D-S System

Plastics Resources, Inc. (PRI) of Logan, Utah, has broadened its business offering by adding a Davis-Standard, LLC coextrusion system for manufacturing rigid PVC fence profiles. The system, installed in the summer of 2005, will support the custom fencing operations of Mountain West Vinyl Products (MWVP), a wholly owned subsidiary of PRI. Fence profiles currently being extruded on the new Davis-Standard line include 5-inch by 5-inch (127mm by 127mm) coextruded posts, 1 1/2-inch by 5 1/2-inch (38mm by 140mm) coextruded rails, and 5/8-inch by 11 3/8-inch (16mm by 289mm) coextruded tongue-and-groove slats/pickets. MWVP offers these profiles in two different wall thicknesses to accommodate customer requirements.

According to Jef Hoggan, PRI's founder, president and CEO, "This is our first turnkey rigid PVC fence profile line and it is performing very well. Even though we got a late start last year, MWVP made our projections for 2005." He added, "Davis-Standard hit all the promised run rates and helped us address the learning curve associated with such a sophisticated system. As we become increasingly familiar with the equipment and the differences in running powder material with these products, we'll improve our rates and efficiency even

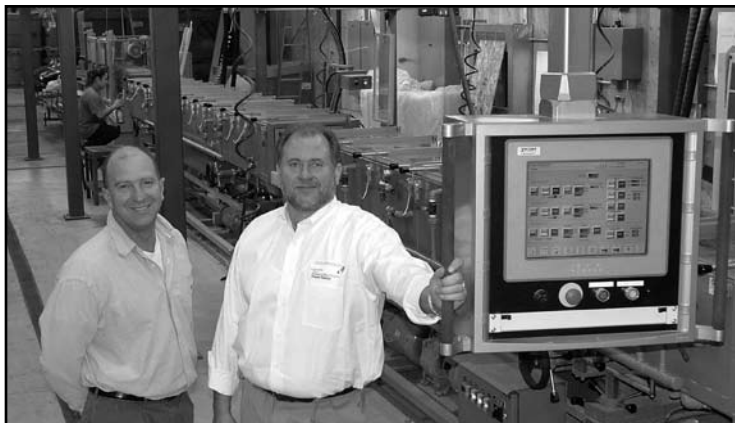

Pictured is production manager Gary Hamblin with founder Jef Hoggan (holding screen) standing next to PRI's new Davis-Standard system.

more." Davis-Standard supplied the complete package including GC-65 (Gemini® Conical, 65mm) and GC-40 (Gemini® Conical, 40mm) co-extruders, a portable chiller, material loading systems, three sets of custom engineered tooling and MESA III control system. PRI, a Davis-Standard customer for 20 years, operates

other Davis-Standard extrusion lines, including some Killion and NRM equipment. Hoggan said the team effort by Davis-Standard, the tooling manufacturer, material suppliers, PRI and MWVP resulted in a high quality system aligned with company goals including a reasonable price tag and short lead time.

"We had a few hurdles along the way, but our Davis-Standard sales engineer was on top of any

issues that arose and was very good at following through on various elements of the project," Hoggan said. "Our goal is to grow this segment of our business at a smart pace that will enable us to maintain our business code of 'Quality with a Short Lead Time for a Good Price.' We will work hard in 2006 to maintain this code for our loyal customers who continue to entrust

PRI with their product needs."

PRI, founded by Hoggan in 1984, started out by extruding clear PVC anti-static packaging for the Integrated Circuit Chips (ICC) business. Since then, the company has expanded into medical, construction and military applications, among others. PRI extrudes specialized plastics for more than 600 customers throughout North America, Europe and Asia. The company's processing range includes PE, PP, PVC, PU, HDPE, PS and ABS, as well as flex, semi-rigid, rigid and high-impact polymers. Profiles are available as thin as .010-inches (.25mm) and as thick as solid

rods. In addition, the company is a solutions partner for hundreds of ESD (Electrostatic Discharge) shipping and handling end-users, suppliers and service organizations.

For more information about PRI's product offering and services, visit [www.pri-plastics.com](http://www.pri-plastics.com). For more information about Davis-Standard's profile systems, contact Wendell Whipple at [wwhipple@davis-standard.com](mailto:wwhipple@davis-standard.com).

## Extrusion Lab *continued from page 1*

use, so we combined the very best technology to offer a significant amount of versatility," explained Richard Tetro, vice president of technology for the Converting Systems Group. "In addition to the extruders and winder, we have a range of feedblocks, dies, feedscrews, and testing equipment to accommodate just about every converting process."

Examples of the line's high-performance components include a three-extruder coextrusion arrangement with drives and motors, automatic hopper loaders, a resin blender, drying capabilities, a five-layer coextrusion feedblock, casting section/extrusion coater/laminator, multiple nip rolls, a thickness measuring gauge, cooling system, air knife, treater, pivot guide, unwind and scrapless winder. Specific to the winder, customers can evaluate their products over a wide tension range using multiple transfer methods. The winder also provides the customer the ability to inline slit down to 2-inch (50mm) widths with or without bleed trims.

The line is controlled by the Integrator PRO process control system. This system provides distributive line control and monitoring of

temperature, line drives and winder, while providing historical trending, diagnostics and other data. In addition, more than 30 feedscrews are available to test shear melt points and run various resins. For specific processes, a screw simulation program is available to determine the best screw for the process and resin. Equipment for comparative measurement of inter-layer gauge uniformity in a coextruded construction is also on site.

According to district sales manager, Adnan Bdour, "This system greatly improves our ability to provide customers with more detailed information. This includes items such as torque feedback, speeds and specific faults in a drive. We also have a lot of features for troubleshooting and maintenance to help customers realize added efficiencies."

In addition to the extrusion pilot lab, a separate large-scale production coating facility, also in Fulton, is available for R&D support, toll coating and small production runs. The BCCM line in this lab now features differential winding and has an operating speed range up to 3,000 feet per minute (900 meters per minute) with web widths up to 40 inches

(1,000mm). As with the pilot lab, customers can test formulations, develop and improve new products and evaluate equipment. The two laboratories combined encompass more than 5,000 square feet (464 square meters) of committed R&D space.

For more information about either laboratory, contact Richard Tetro at [tetro@bc-egan.com](mailto:tetro@bc-egan.com).



**1 Extrusion Drive**  
Pawcatuck, CT 06379 U.S.A.  
[www.davis-standard.com](http://www.davis-standard.com)  
email: [info@davis-standard.com](mailto:info@davis-standard.com)

**Telephone: +1 860-599-1010**  
**Fax: +1 860-599-6258**

**24/7 Support**  
**Extrusion Systems: +1 800-480-8105**  
**Converting Systems: +1 800-338-3660**

VOLUME 34 • NUMBER 2