

KEYSTONE REVIEW

OCTOBER

NOVEMBER

DECEMBER

2007

D-S to Showcase Versatile Product Line at K 2007

During K 2007 Davis-Standard will display extrusion equipment engineered to meet the economic and production demands of today's plastics marketplace. Equipment to be shown in **hall 16, stand A43** will include the Euro Blue™ II extruder, HPE extruder, and a system for manufacturing cotton swab sticks. A Davis-Standard cold feed rubber extruder mounted on an Uth roll-ex® 70 gear extruder common base/assembly will be shown at the Uth GmbH booth in **hall 15, stand A50**. Company representatives and information about Davis-Standard's Converting Systems and Extrusion Systems business groups in Europe will be available throughout the show.

Euro Blue™ II Extruder, 75mm – This extruder is an upgraded version of the original Euro Blue™ introduced in 2004. It provides high quality specifications and processing rates at a reasonable cost. In stock machines can be delivered in as quickly as one week

based on location. The Euro Blue II includes a double reduction gearbox with helical carburized gears, an integral high capacity thrust bearing, cast iron feed section, four-zone DS1000 bi-metallic barrel assembly with heated clamp arrangement, and DSBM-T™ high performance barrier mixing feedscrew, among other high performance features. It also comes with a two-year warranty and support from D-S Brookes' UK-based technical and aftermarket services. Like its predecessor, this model is



A line with an all-in-one Betopac machine for pulling, cutting and packing small serrated tubes will manufacture cotton swab sticks during the show.

engineered for custom profile and tubing applications, as well as basic wire and cable processes. The extruder range currently

K 2007 continued on page 5

Integra Adds Capabilities with Extrusion Laminating/Coating Line

Integra Plastics of Madison, South Dakota, is expanding its product offering with a newly installed extrusion laminating and coating line from the Converting Systems Group of Davis-Standard, LLC. The line, installed in June, will enable the company to produce a broad spectrum of products in-house for use in the agriculture,



The new line will enable Integra to do coating and laminating in-house, helping them keep an even tighter grip on quality control and competitive pricing.

construction, landfill applications and marine markets, as well as offer laminating services. Integra, established in 1991, has

Integra continued on page 2

IN THIS ISSUE

- Patented Toolsafe System Helps Prevent Damage p. 2
- DS⁵ System to Streamline Customer Service p. 2
- New DS8000 Wear Resistant Barrel Lining p. 3
- John Christiano to Present at Bioplastics Conference p. 3
- Duane Smith Authors TAPPI Publication p. 3
- PRI Increases Production with Fence Line p. 4
- Extruders Support Lab at UMASS Lowell p. 6

24/7 Support

Extrusion Systems: +1 800-480-8105
Converting Systems: +1 800-338-3660
Europe: +49 173-710-6407

On Time, Every Time

D-S Davis-Standard®

New D-S Support System to Streamline Customer Service

A new support system from the Converting Systems group of Davis-Standard, LLC will enable faster, more convenient customer service via a high speed internet connection. Called the Davis-Standard Secure Service Support System, or DS⁵, this system is designed to help customers avoid lengthy downtimes by giving Davis-Standard service personnel and engineers immediate access to customer equipment via a safe and secure internet connection. With DS⁵, service personnel can more easily respond to customer needs and can diagnose and fix problems regardless of their location in the world.

“We wanted to come up with a way to eliminate unnecessary downtime for our customers while giving our service personnel and engineers a faster way to solve equipment issues,” explained Tarek Adly, Product Manager, Drives and Controls. “With DS⁵, we’re able to utilize a secure, high speed internet connection to respond more quickly, and hopefully save our customers money by getting them up and running sooner. It simplifies the process and makes our service

personnel more accessible to all of our customers.”

How it works: A DS⁵ computer system is

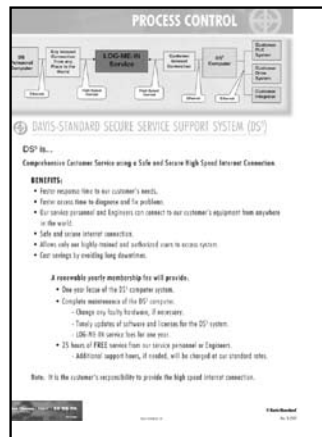

installed at the customer's site. One end is connected to the Internet and the other is connected to the customer's equipment via a PLC, Drive, Integrator, etc. The internet connection flows outward through the

customer's firewall following their internet safety connection standards. The internet ties the DS⁵ computer to the "LOG-ME-IN" service, which protects the computer connection by requiring a specified and unique user name and password. As added security, the LOG-ME-IN service will only allow authorized Davis-Standard personnel to connect to the DS⁵ computer system. Davis-Standard personnel must also have a unique user name and password to connect. Once connected, they can access the customer's DS⁵ system, evaluate the situation from their computer screen, and make recommendations. As added security, user names and passwords are changed periodically.

Use of DS⁵ requires a renewable yearly membership fee. With this membership, customers receive a one-year lease of the DS⁵ computer system, complete maintenance of the system including software and license updates, and 25 hours of customer service. Additional support hours, if needed, will be charged at Davis-Standard's standard service rate.

For more information about DS⁵, contact Tarek Adly at adlyt@bc-egan.com.

Integra *continued from page 1*

seen significant growth over the past few years due to the healthy economy, unique proprietary processes and customer-driven service. Prior to the installation of the new line, Integra's operation was primarily focused on the conversion of coated fabric and laminated fabric into finished products. Now Integra will be able to do much of the coating and laminating inside, keeping an even tighter grip on quality control and competitive pricing, both key contributors to the company's success.

“The new line will expand the number of products offered by Integra, products that many of our customers have already expressed an interest in purchasing,” said Clark Lee, Integra's Director of New Business Development. “It also takes us a step closer to our goal of adding 'one-stop' shopping while further improving our commitment to customer service after the sale, quality and pricing.”

The new custom-built line includes a 4-inch (100mm) extruder with in-line resin blending capabilities, a 90-inch (2,286mm) extrusion laminator, shaftless unwinds and jumbo surface winder. The extrusion laminator has the capability to laminate three substrates in one pass, or to coat one. The unwinds use pneumatic actuated web threading belts to insert the web into the splicing nip for a continuous and safe operation. The winder features rotary knife transfer technology for cutting a wide range of engineered, laminated fabric construction, and for continuous operation during

transfers. The machine is also modular in design with the drives and controls pre-mounted for quick and easy installation. According to Lee, the line speed will vary dramatically depending on the material being produced, but the extruder will typically run at around 1,000 pounds (454 kg) per hour.

“Our customers range from commodity crop processors, landfills and wastewater treatment facilities, to construction and oilfield supplies distributors and ethanol processing plants,” explained Lee. “This line will allow us to provide excellent long-term value and will help us maintain our niche of servicing customers with more specialized products.”

Some of Integra's products include landfill and silage covers, vapor barriers, industrial packaging, and pond/containment/canal liners. This is the company's first purchase from Davis-Standard, LLC.

Says Lee, “I knew Davis-Standard had a history of building the type of equipment Integra needed, and would be knowledgeable of the special considerations we wanted included in this line. We were impressed by their ability to work quickly and efficiently through the design phase, and deliver the equipment as specified and on time.”

For more information about Integra Plastics, visit www.integraplastics.com. For more information about Davis-Standard, LLC extrusion coating and laminating equipment, contact Ken Piora at piorak@bc-egan.com or visit www.bc-egan.com.

Toolsafe System Patented

The newly patented Toolsafe system from Davis-Standard, LLC is engineered to improve blow molding processes by preventing damage to head tooling from inaccurate pin and die adjustment. Using Toolsafe, blow molders are able to lower hydraulic pressure to the programming cylinder to reduce the possibility of damage to head components after a product change. Toolsafe, introduced in 2004 but patented this spring, is standard on all new Davis-Standard blow molding equipment and can be retrofitted to most other equipment.

This technology is especially beneficial for blow molders with multiple product changes, requiring adjustments to the pin and die clearance to accommodate the wall thickness of various parts. Each time a modification is made, the machine operator must re-calibrate the pin and die clearance by electrically adjusting the position of the programming cylinder. If adjusted incorrectly, the pin and die can come into contact with one another. When this occurs, the high hydraulic pressure required by the programming cylinder, usually 2,000 psi or higher, can damage the pin, die or other extrusion head components. Toolsafe lowers pressure to the cylinder, except during the actual flow of plastic from the head to form the parison, to eliminate this potential problem.

For more information about Toolsafe, contact Rusty D'Angelo at rdangelo@davis-standard.com.

New Publication from TAPPI Press by R. Duane Smith

Davis-Standard, LLC is pleased to announce that a new TAPPI publication, *Roll and Web Defect Terminology – 2nd Edition* is authored by R. Duane Smith, Product Manager – Specialty Winding. Smith, who has over 35 years experience in the web handling arena, worked with 22 industry experts and 16 contributing editors to compile this impressive resource. *Roll and Web Defect Terminology – 2nd Edition* has been recognized by many in the web handling industry as the most comprehensive reference guide available for addressing roll and web defects. This edition features 224 defects commonly found in paper, film and nonwoven webs and wound rolls, many of which did not exist when the first edition was written 15 years ago.

“The group who worked with me on this collaboration is extremely knowledgeable and talented. The chapter champions and consulting editors have more than 500 years of combined web handling and winding experience. Their valuable expertise makes this a tremendous resource to aid in the battle to eliminate roll and web defects,” explained Smith. “Not only is this a reference book, it is a tool for web producers, converters, printers and their customers to communicate using common language to properly identify

roll and web defects. This is the first and most important step in the defect problem solving process.”

Within the book’s more than 400 pages are 10 chapters and 287 images covering general roll defects, web profile defects, edge defects, roll and web wrinkling defects, papermaking web defects, calendaring web defects, aqueous coating web defects, film extrusion and lamination defects, web handling defects and slitting defects. Detailed information can be found for each individual defect including a description and illustration, commonly used terms, cross references, causes and remedies, and other sources of published information. In a nutshell, *Roll and Web Defect Terminology – 2nd Edition* is a systematic guide written in common language to provide a clean and concise format for describing roll and web defects.

“Many industry experts have endorsed this book as invaluable in identifying and troubleshooting defects, saying that it is a ‘must have’ publication,” added Smith. “We are excited to see how it benefits the industry.”

Roll and Web Defect Terminology – 2nd Edition is available through TAPPI Press at http://www.tappi.org/s_tappi/doc_

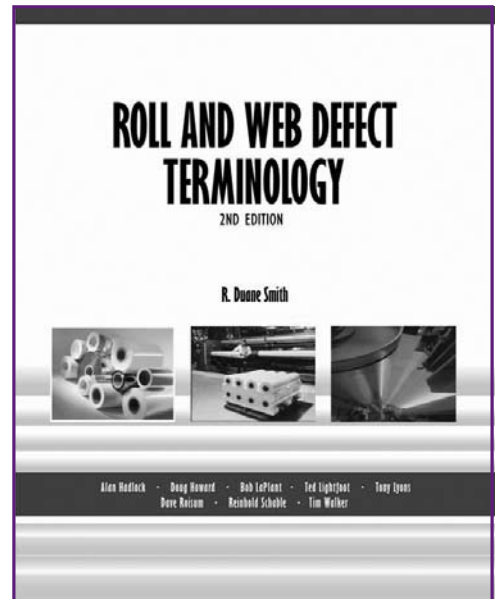

This edition is recognized by many in the industry as being the most comprehensive reference guide available for addressing roll and web defects.

[bookstore.asp?CID=189&DID=554943](http://www.amazon.com/bookstore.asp?CID=189&DID=554943) or by calling 1-800-466-9431 (U.S. and Canada) or 1-770-446-1400 (Worldwide) and ordering item #0101R318.

DS8000 Products Engineered for Abrasive and Corrosive Compounds

Davis-Standard, LLC recently added to its bi-metallic barrel lining product series to support applications with highly abrasive and corrosive properties. The new DS8000 wear resistant barrel lining material is a nickel based alloy with a high percentage of tungsten carbide particles suspended within its matrix. This corrosion and abrasive wear resistant lining is recommended for those processes requiring highly filled or reinforced compounds, high-temperature resins, silicones, vinyl resins, polyethylenes, LLDPE, HMWPE and blends.

Davis-Standard also offers three other options within this product line, the DS1000, DS2000 and DS6000. The DS1000 is an iron based barrel lining for general purpose wear environments and is fitted in nearly all Davis-Standard machines as a standard item. Similar to the DS1000, the DS2000 alloy provides additional wear resistance for accommodating a higher degree of filler or reinforcement in the material to be processed and also a moderate degree of corrosion resistance. The DS6000 is nickel based like the DS8000 and is designed for



D-S Brookes barrels are engineered to support all types of processing conditions.

use in corrosive wear environments when processing compounds such as those with flame retardants, fluoropolymers and high-temperature resins.

This product line is manufactured by D-S Brookes Limited, Davis-Standard’s Extrusion Systems Europe subsidiary in the UK. For more information, contact Mark Woodgate at mwoodgate@dsbrookes.com or John Radovich at jradovich@davis-standard.com.

John Christiano to Present at Conference

John Christiano, Davis-Standard’s Director of Extrusion Processing Technology, will present a paper on single screw processing technology at the second annual Bioplastics Processing Conference, December 4 – 5 in Charlotte, North Carolina. The presentation is entitled, “Optimization of a High Performance Barrier Screw for Processing Bio-Polymers, The Eco-DSB® Barrier Screw.”

The conference, hosted by *Plastics Technology*, attracts processors and industry experts from around the country. In addition to Christiano’s presentation, other topics will include thermoforming, injection and blow molding process developments; process modifications for film, sheet, fibers and foaming for bioplastics; material handling and plant management; packaging applications and opportunities; material advances for renewable resins; and degradability issues and developments.

For more information, visit www.ptonline.com/conf/biocon/.

PRI Increases Production with Second D-S Fence Line

Plastics Resources, Inc. (PRI) of Logan, Utah, recently boosted production of rigid PVC fence profiles by installing a second Davis-Standard, LLC coextrusion system. The new system, identical to PRI's first system installed in 2005, is reducing lead times and tooling changes while increasing outputs and production time. Both Davis-Standard systems support the custom fencing operations of Mountain West Vinyl Products (MWVP), a wholly owned subsidiary of PRI.

Jef Hoggan, PRI founder, President and CEO said, "With the two lines, we have increased outputs around 115 percent with less down time spent changing over our tooling for other products. This has enabled us to build a bit of inventory. We are also running more in line with our schedule and with shorter lead times for customers."

As with the last system, the line is set up for manufacturing 5-inch by 5-inch (127mm by 127mm) coextruded posts, 1.5-inch by 5.5-inch (38mm by 140mm) coextruded rails, and 5/8-inch by 11 3/8-inch (16mm by 289mm) coextruded tongue-and-groove slats/pickets. MWVP offers these profiles in two different wall thicknesses to accommodate customer requirements. The company's fencing products have been highly successful in the marketplace. PRI's sales for the vinyl fence market have increased approximately 75 percent since 2005 and are still growing.

"Our growth has primarily resulted from excellent quality of finished products and shorter lead times than competitors,"

explained Hoggan. "Our first Davis-Standard line has treated us very well and we have exceeded our projections. The second line is also performing well and the service has been outstanding."

Davis-Standard supplied the complete package including GC-65 (Gemini® Conical, 65mm) and GC-40 (Gemini Conical, 40mm) co-extruders, a portable chiller, material loading systems, three sets of custom engineered tooling and MESA III control system. PRI, a Davis-Standard customer for 20 years, operates other Davis-Standard extrusion lines, including some Killion and NRM Extrusion equipment.

As for the future of PRI's vinyl fence business, Hoggan is optimistic. "We are growing and being aggressive in the vinyl fence market in the Western U.S. along with the rest of our business product markets," he said. "We look forward to serving our expanding customer base with the excellent customer service and quality products that we are known for in the industry."

PRI, founded by Hoggan in 1984, started out by extruding clear PVC anti-static packaging for the Integrated Circuit Chips (ICC) business. Today, PRI extrudes specialized plastics for more than 600



Jef Hoggan, PRI founder, President and CEO, has boosted production by installing a second Davis-Standard fence line system.

customers throughout North America, Europe and Asia. The company's processing range includes PE, PP, PVC, PU, HDPE, PS and ABS, as well as flex, semi-rigid, rigid and high-impact polymers. In addition, the company is a solutions partner for hundreds of ESD (Electrostatic Discharge) shipping and handling end-users, suppliers and service organizations. PRI also manufactures embossed carrier tape (tape and reel) solutions for suppliers and users of surface mount technology (SMT) and other devices that require assembly automation.

For more information about PRI's product offering and services, visit www.pri-plastics.com. For more information about Davis-Standard's fence systems, contact Wendell Whipple at wwhipple@davis-standard.com.



Jason Baird, Ph.D.



Tom Brown



Jeff Hedegore



Adrian Mawdsley



David Patton



John Turkowski



Tom Welsh

Personnel News

Jason Baird, Ph.D. has recently joined the Extrusion Systems Group as a Process Development Engineer in the company's Technical Center. His work will focus on process development of extrusion systems.

Tom Brown has returned to Davis-Standard as a Field Sales Engineer for the Aftermarket Department, having spent the last several years as a Regional Sales Manager for American Kuhne. He will work from his home office in Plano, Texas. His territory will include the southern states of Texas, Oklahoma, Arkansas, Louisiana, Mississippi, Alabama, Tennessee, North Carolina, South

Carolina, Georgia, and Florida.

Jeff Hedegore has also joined Davis-Standard as a Field Sales Engineer for the Aftermarket Group. He has spent the last four years as Regional Manager/Extrusion Product Manager at Spirex. He will work from his home office in Grove City, Pennsylvania. His territory will include Wisconsin, Illinois, Michigan, Indiana, Kentucky, Ohio, West Virginia, Western New York, Western Pennsylvania, and Ontario, Canada.

Adrian Mawdsley has joined D-S Brookes Ltd. as a Sales Engineer to oversee sales and service in southern and northern England and parts of Europe.

David Patton has returned to the company

in the position of Project Manager for the wire and cable product line. He will oversee and facilitate sales and cross-functional project teams to ensure customer satisfaction for wire and cable projects worldwide.

John Turkowski has joined the company as Director, Continuous Improvement. He will be responsible for the company's GROW program, which is Davis-Standard's lean program with initiatives to improve business processes and reduce cycle times.

Tom Welsh has joined D-S Brookes Ltd. in the position of Sales Engineer. His responsibilities will include sales and service in southern and northern England and parts of Europe.

D-S to Focus on Process Improvement at Rubber Expo 2007

Rubber extrusion technology designed for process improvement and cost savings will be exhibited by Davis-Standard, LLC, **booth #520**, during the upcoming Rubber Expo in Cleveland, Ohio, October 16-18. Included in the display will be a new 3 1/2-inch (90mm) DSREV rubber extruder, highly efficient barrier screw, patented ELF feed section and Model 2000 crosshead. In addition to the equipment, a DVD kiosk will be available to showcase Davis-Standard's full range of elastomer extrusion capabilities.

DSREV Extruder – The 3 1/2-inch (90mm) DSREV multipurpose extruder being shown will exhibit several design changes that improve the extruder's economics, efficiency and performance. This is the second generation of this extruder model. Some of the changes include pre-assembled screw and head injection units, a redesigned base, a simplified cooling and wiring system, and redesigned double-pass heaters for ease of piping and wiring. All improvements are geared toward simplified maintenance, improved access to machine components and

cost-effective operation.

ELF Feed Section – Davis-Standard's recently patented elastomer leakage-free (ELF) feed roll assembly helps minimize the leakage and scrap created during elastomeric extrusion processes. The invention was patented earlier this year by Davis-Standard engineers. The ELF provides effective feedback of overflow material and can be retrofitted to existing extruders to provide cost savings. It features a shell, feed roll seal plates and feed roll end plates to curtain leakage. The material is redirected back to the feed section by means of a varying bore diameter of the shell and grooves contained in both the feed roll seal plates and feed roll end plates. All major components are coated with a solid, dry lubricant coating to reduce friction. The result is a cleaner and more efficient elastomeric extrusion process that helps processors save on material and maintenance costs.

2-inch (50mm) Crosshead - The Model 2000 hydraulic crosshead reduces scrap and

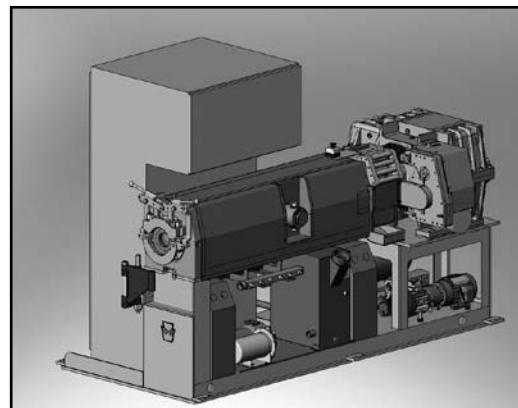

The second generation DSREV extruder will be featured at Davis-Standard's booth #520 during the Rubber Expo.

enables faster start-up times. The crosshead features hydraulic actuation of the flow diverter/core tube for quick tooling changes and simplified cleaning. The core tube design allows minimal deflection to maintain concentricity at various screw speeds. All inside surfaces are Armalloy coated for better wear resistance and material flow. The core tube thrust bearing facilitates easy pin adjustment to change wall thickness while running. Models are available for 2-inch (50mm) and 3-inch (75mm) diameters.

For more information prior to the show, contact Joe Wnuk at jwnuk@davis-standard.com.

K 2007 *continued from page 1*

includes sizes of 50mm, 60mm, 75mm, and 90mm in 24:1 configurations.

HPE-100A Extruder – This 25mm extruder exemplifies processor demands with a small footprint, performance features, and a fast delivery for coextrusion and multilayer applications. Available in sizes ranging from 19mm to 44mm, the HPE utilizes a direct drive motor rather than belts and sheaves, and has a small footprint for close proximity to the common die. It swivels on a column to permit positioning at any angle and vertical adjustment is accomplished by means of a lift screw. All sliding/swiveling components can be locked firmly into place for rigid positioning. The HPE is also available in a horizontal configuration.

Cotton Swab Stick Line – A line with an all-in-one Betopac machine for pulling, cutting and packing small serrated tubes will manufacture cotton swab sticks during the show. The Betopac is capable of packaging up to 4,500 sticks per minute, but will package around 2,000 to 2,500 sticks per minute at the show. This machine simplifies the downstream process by automatically placing sticks into a tray or box and staging them for a secondary process. The sticks at the show

will have a 2.5mm nominal OD, 1.9mm ID and length of 72mm with an OD tolerance of +/- .05mm, and cut length tolerance of +/- .5mm. Davis-Standard will run polypropylene with an MFI of between 3.0 and 3.5. The line will be powered by a 60mm Euro Blue II extruder.

Cold Feed Rubber Extruder/Uth roll-ex® 70 – Davis-Standard and Uth have combined technologies to exhibit a 90mm cold feed rubber extruder as an option to use as a screw feeder when connected to a roll-ex 70 gear extruder. This arrangement, shown for the first time, enables precision extrusion of cold feed rubber preforms for post processing of compression molding. This precision extrusion complex will showcase the extrusion process knowledge of Davis-Standard with the gear pump and straining expertise of Uth. The cold feed extruder features a high performance low-shear feedscrew, and has a smooth barrel design for cost-effective maintenance of both the feedscrew and barrel. The roll-ex gear extruder is modular in design and offers advantages such as a minimal material dwell time, low temperature increase and a hydraulic system that gives operators access to all major components.

Holiday Schedule

Davis-Standard's manufacturing facilities will be observing the following holiday schedule in November and December. We wish you a happy and healthy holiday season and prosperous 2008!

United States

Thanksgiving	November 22
	November 23
Christmas	December 24
	December 25
New Year's	December 31
	January 1

China

New Year's	January 1
------------	-----------

Germany

All Saints	November 1
Repentance Day	November 21
Christmas	December 25
	December 26
New Year's	December 31
	January 1

United Kingdom

Christmas	December 25
	December 26
	December 27
	December 28
New Year's	December 31
	January 1

D-S Extruders Augment UMass Lowell Lab Capabilities

Two Davis-Standard, LLC extruders will support educational and R&D laboratory operations at the University of Massachusetts Lowell (UML). The two 1 1/4-inch (30mm) 24:1 L/D extruders were donated to UML earlier this year by a global leader in the medical device industry upon completion of an R&D project. The extruders were in good condition, but needed upgrades to address UML's diverse lab requirements. Davis-Standard rebuilt the extruders and improved functionality by installing new discrete electronic controls and drives. The recently upgraded extruders will be used in two different labs. One will be set up as a tubing line for SPC (Statistical Process Control) studies, and the other will be used for theoretical and experimental output studies as well as instruction on the basics of controls, instrumentation, safety and operation. The extruders will also be used for coextrusion applications.

"Davis-Standard has an outstanding reputation as a manufacturer of high quality extrusion equipment," said Professor Robert Malloy, Chairman of UML's Department of Plastics Engineering. "The control and drive upgrades to these extruders will enable us to support multiple applications and will benefit our laboratory for years to come."

In addition to the Davis-Standard extruders, UML's lab features a Davis-Standard Killion lab line. The University's program was established in 1954 and offered well-equipped lab facilities from the start. Today, the UML Department of Plastics Engineering has 20,000 square feet (1,859 square meters) of dedicated laboratory space that is used by both undergraduate

and graduate students. Industry leaders have been instrumental in helping the University maintain and improve its lab by donating or supplying equipment, machinery, materials and software at a significantly reduced cost.

Several exciting projects are currently underway at UML's plastics' lab. Examples include development of PHB process formulations; nanomanufacturing research including electrospinning of nano fibers



and replication of nano features by various molding techniques; and the development of a self-regulating valve to reduce surging during an extrusion process. Most of the major research projects at UML are funded by government agencies such as the National Science Foundation (NSF) and Department of Defense (DOD). However, about 40 percent of the funding is from industry. In most cases, UML's lab provides a venue to companies lacking the expertise or lab capabilities to conduct R&D projects in-house. Many of these projects involve the development of new materials, blends or additives, or may be process related. To support these demands, UML's lab is

equipped for sheet extrusion, rods and tubes, blown film, twin screw compounding and coextrusion applications.

According to Malloy, "Our lab is busy, but we always welcome the opportunity to talk or meet with companies interested in doing research projects. Scheduling is sometimes an issue because the best time to begin a project is at the start of the fall semester in September or at the start of the summer session in May. But, we can usually work out a schedule and accommodate most requests."

As for the impact of the laboratory on students at UML, Malloy says that the program produces plastics engineers that have a "good balance of theoretical and experimental capability." Both undergraduate and graduate students are required to take hands-on lab courses in plastics processing. Students can also utilize lab equipment for research, depending on the project. UML most recently started offering online graduate classes in the areas of plastics materials and processing to open up the program to practicing engineers around the world. In this regard, there are also plans for developing lab exercises that can be completed remotely. For more information about the Department of Plastics Engineering at UML, contact Robert Malloy at robert_malloy@uml.edu or visit the school's website at <http://plastics.uml.edu>. For more information about Davis-Standard extruder upgrades, contact Paul Banks at pbanks@davis-standard.com.

Davis-Standard®

1 Extrusion Drive
Pawcatuck, CT 06379 U.S.A.
www.davis-standard.com
email: info@davis-standard.com

Telephone: +1 860-599-1010
Fax: +1 860-599-6258

24/7 Support

Extrusion Systems:
+1 800-480-8105

Converting Systems:
+1 800-338-3660

Europe:
+49 173-710-6407

To update your Keystone subscription information with new addresses, contact names, e-mails, etc., please contact Wendy Smith at wsmith@davis-standard.com.

VOLUME 35 • NUMBER 4

Inventory for Sale on Website

Surplus inventory available on the Davis-Standard website, www.davis-standard.com, is listed below. For pricing, see the website or e-mail us at surplus@davis-standard.com.

New In Stock

- GC-65 Medium Shear Conical Screws - #350764-1 for GC-65 Extruder
- GC-65 Conical Barrel - #350768 for GC-65 Extruder
- 1-inch (25mm) 24:1 Killion lab extruder, lightly used in Killion lab and refurbished to new condition. Contact Simon Dominey at sdominey@davis-standard.com.
- 2-inch (50mm) grooved feed extruder

Other Equipment

- DTEX 113 – Flender gearcase
- DTEX 21 – Screw shafts, screw elements, and flender gearcase

- DTEX 58 – Various parts including screw elements
- DTEX 69 – Various parts including screw elements, screens, vent insert
- DTEX 82.5 – Flender gearbox, strand die
- TAE 020 – Heat exchanger MTA model TAE 020. Italian manufacturer 400/3/50
- Mandrel – Cooling mandrel to produce 50" wide HIPS foam sheet
- Chiller – Advantage Chiller 380V/50hz Model BI – 1.5 R5620
- Chillers – 3 AEC Chillers, Model PCA-100Q, 0.6 Ton Chillers, 380/3/50
- Twin Screws – New set of GC8 high shear conical twin screws designed for high quality, low volume
- Dynisco melt pump with controls and motor suitable for interface with a 1-inch (25mm) extruder. Contact Simon Dominey at sdominey@davis-standard.com.